



Positioning & Lifting
Equipment Specialists



G4 Series Power Pump

Continuous Operation, Heavy Duty Power Pump

G4173M Shown
See table for additional models

- ✓ Powered by a 115V - 60Hz, 1-1/2 hp induction motor (1,725 rpm); low startup voltage, draws 16 amps at full load (230V models available).
- ✓ High performance two-stage pump provides higher cross-over pressure for faster cycle times and equipment operation; 55 cubic inches / minute @ 10,000 PSI.
- ✓ Precision designed valve offers reliability and secure load holding; external adjustable relief standard on all models.
- ✓ Reservoirs available in 1.5 - 20 gallons; welded steel design.
- ✓ Ideal for use with mid sized hydraulic cylinders or tools.
- ✓ Quiet operation, plus heavy duty design for extended applications.



For over a century, Simplex has been known throughout the industry for its industrial positioning equipment capabilities. The G4 Series Power Pump is of no exception to that fact.

This 2 stage, high performance pump provides higher crossover pressure for faster cycle times and equipment operation; 55 cubic inches / minute @ 10,000 psi. Available in 1.5 through 20 gallon steel reservoirs and is the ideal pump for mid-sized cylinders or tools.



G4 Series

Continuous Operation, Heavy Duty Power Pump

Model Shown
G4173M

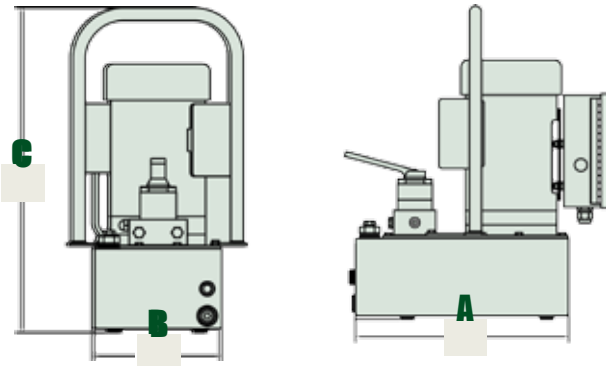

Usable Reservoir Capacity Gallons	A	B	C
	(in)	(in)	(in)
1.5	15.13	8.75	22.34
2.5	17	9.75	22.34
5	25.10	11.75	21
10	25.10	11.75	25.25
20	28	19.6	25.25

Product Ordering & Specifications

Model	Pressure Rating (psi)		Output Flow (cu.in./min.)		Motor Spec.		Valve Type	Pendant Control	Reservoir Capacity	Weight (lbs)
	1st Stage	2nd Stage	1st Stage	2nd Stage	(vac)	(amps)				
G4102	1,100	10,000	400	55	115	16	Dump	Motor	1.5	38
G4103	1,100	10,000	400	55	115	16	Dump	Motor	2.5	45
G4122	1,100	10,000	400	55	115	16	2W, 2P	Optional Motor	1.5	52
G4132	1,100	10,000	400	55	115	16	3W, 3P	Optional Motor	1.5	53
G4133	1,100	10,000	400	55	115	16	3W, 3P	Optional Motor	2.5	63
G4162	1,100	10,000	400	55	115	16	3W, 3P	Motor / Solenoid	1.5	57
G4163	1,100	10,000	400	55	115	16	3W, 3P	Motor / Solenoid	2.5	67
G4142	1,100	10,000	400	55	115	16	4W, 3P	Optional Motor	1.5	53
G4143	1,100	10,000	400	55	115	16	4W, 3P	Optional Motor	2.5	63
G4172	1,100	10,000	400	55	115	16	4W, 3P	Motor / Solenoid	1.5	57
G4173	1,100	10,000	400	55	115	16	4W, 3P	Motor / Solenoid	2.5	67

* For 230 VAC pump use "2" in the 3rd character of the model number. Motor specifications 0.8 kw single phase, 10 amps @ 230 VAC.

Additional Pump Configurations

